

Nios[®] II

Creating Multiprocessor Nios II Systems Tutorial



101 Innovation Drive
San Jose, CA 95134
(408) 544-7000
<http://www.altera.com>

TU-N2033005-1.0

Copyright © 2005 Altera Corporation. All rights reserved. Altera, The Programmable Solutions Company, the stylized Altera logo, specific device designations, and all other words and logos that are identified as trademarks and/or service marks are, unless noted otherwise, the trademarks and service marks of Altera Corporation in the U.S. and other countries. All other product or service names are the property of their respective holders. Altera products are protected under numerous U.S. and foreign patents and pending applications, maskwork rights, and copyrights. Altera warrants performance of its semiconductor products to current specifications in accordance with Altera's standard warranty, but reserves the right to make changes to any products and services at any time without notice. Altera assumes no responsibility or liability arising out of the application or use of any information, product, or service described herein except as expressly agreed to in writing by Altera Corporation. Altera customers are advised to obtain the latest version of device specifications before relying on an information and before placing orders for products or services.



About This Tutorial	ix
How to Find Information.....	v
How to Contact Altera	vi
Typographical Conventions.....	vii
Designing Multiprocessor Systems	9
Introduction	9
Assumptions about the Reader.....	Error!
Bookmark not defined.	
Benefits of Multiprocessor Systems	10
Nios II Multiprocessor Systems	10
Hardware Design Considerations.....	11
Autonomous Multiprocessors	11
Multiprocessors that Share Resources.....	12
Sharing Resources in a Multiprocessor System	12
Sharing Memory.....	14
The Hardware Mutex Core	15
Nios II Systems Without a Mutex Core.....	16
Sharing Peripherals Between Multiple Processors.....	16
Multiprocessors & Overlapping Address Space	17
Software Design Considerations	19
Program Memory	19
Boot Addresses.....	23
Running & Debugging Multiprocessor Systems from the Nios II IDE	25
Building & Running Software on a Nios II Multiprocessor	30
Introduction	27
Hardware and Software Requirements.....	27
Creating the Hardware System	28
Getting Started with a Standard Example Design.....	28
Adding a Second Processor.....	30
Adding a Third Processor.....	30
Adding a Timer for cpu2	31
Adding a Timer for cpu3	32
Adding a Hardware Mutex.....	32
Adding a Message Buffer Memory	33
Connecting Shared Resources.....	33
Setting Reset and Exception Addresses	35
Setting Reset and Exception Addresses for cpu1	35
Setting Reset and Exception Addresses for cpu2	35
Setting Reset and Exception Addresses for cpu3	36

Generating and Compiling the System	36
Creating Software for the Multiprocessor System	37
Starting the Nios II IDE.....	37
Creating a Software Project for cpu1	38
Creating a Software Project for cpu2	41
Creating a Software Project for cpu3	42
Building the Software Projects.....	43
Setting up the Nios II IDE for Multiprocessor Debug	43
Creating a Debug Configuration for Each Processor.....	44
Creating a Multiprocessor Collection.....	46
Starting the Multiprocessor Collection.....	47
Debugging the Software Projects on the Board	47



About This Tutorial

This tutorial describes the features of the Nios II processor and SOPC Builder tool used for creating systems with two or more processors that work together to share common resources and with an example, guides you through the steps of creating a multiprocessor system.

The following table shows the revision history of this document.

Date	Description
April 2005	First publication.

How to Find Information

- The Adobe Acrobat Find feature allows you to search the contents of a PDF file. Click the binoculars toolbar icon to open the Find dialog box.
- Bookmarks serve as an additional table of contents.
- Thumbnail icons, which provide miniature previews of each page, provide a link to the pages.
- Numerous links, shown in green text, allow you to jump to related information.

How to Contact Altera

For the most up-to-date information about Altera products, go to the Altera world-wide web site at www.altera.com. For technical support on this product, go to www.altera.com/mysupport. For additional information about Altera products, consult the sources shown below.





Information Type	USA & Canada	All Other Locations
Technical support	www.altera.com/mysupport/	altera.com/mysupport/
	(800) 800-EPLD (3753) (7:00 a.m. to 5:00 p.m. Pacific Time)	+1 408-544-7000 (7:00 a.m. to 5:00 p.m. (GMT -8:00) Pacific Time)
Product literature	www.altera.com	www.altera.com
Altera literature services	literature@altera.com	literature@altera.com
Non-technical customer service	(800) 767-3753	+1 408-544-7000 (7:30 a.m. to 5:30 p.m. (GMT -8:00) Pacific Time)
FTP site	ftp.altera.com	ftp.altera.com

Typographical Conventions

This document uses the typographical conventions shown below.

Visual Cue	Meaning
Bold Type with Initial Capital Letters	Command names, dialog box titles, checkbox options, and dialog box options are shown in bold, initial capital letters. Example: Save As dialog box.
bold type	External timing parameters, directory names, project names, disk drive names, filenames, filename extensions, and software utility names are shown in bold type. Examples: f_{MAX} , \qdesigns directory, d: drive, chiptrip.gdf file.
<i>Italic Type with Initial Capital Letters</i>	Document titles are shown in italic type with initial capital letters. Example: AN 75: High-Speed Board Design.
<i>Italic type</i>	Internal timing parameters and variables are shown in italic type. Examples: t_{PIA} , $n + 1$. Variable names are enclosed in angle brackets (< >) and shown in italic type. Example: <file name>, <project name>.pof file.
Initial Capital Letters	Keyboard keys and menu names are shown with initial capital letters. Examples: Delete key, the Options menu.
"Subheading Title"	References to sections within a document and titles of on-line help topics are shown in quotation marks. Example: "Typographic Conventions."
Courier type	Signal and port names are shown in lowercase Courier type. Examples: data1, tdi, input. Active-low signals are denoted by suffix n, e.g., resetn. Anything that must be typed exactly as it appears is shown in Courier type. For example: c:\qdesigns\tutorial\chiptrip.gdf. Also, sections of an actual file, such as a Report File, references to parts of files (e.g., the AHDL keyword SUBDESIGN), as well as logic function names (e.g., TRI) are shown in Courier.
1., 2., 3., and a., b., c., etc.	Numbered steps are used in a list of items when the sequence of the items is important, such as the steps listed in a procedure.
■ ● ●	Bullets are used in a list of items when the sequence of the items is not important.
✓	The checkmark indicates a procedure that consists of one step only.

Typographical Conventions

Visual Cue	Meaning
	The hand points to information that requires special attention.
	The caution indicates required information that needs special consideration and understanding and should be read prior to starting or continuing with the procedure or process.
	The warning indicates information that should be read prior to starting or continuing the procedure or processes.
	The angled arrow indicates you should press the Enter key.
	The feet direct you to more information on a particular topic.

Introduction

Any system which incorporates two or more microprocessors working together to perform a task is commonly referred to as a multiprocessor system. Developers using Altera's Nios II processor and SOPC Builder tool can design and build multiprocessor systems that share resources quickly. SOPC Builder is a system development tool for creating SOPC design systems based on processors, peripherals, and memories. A Nios II processor system refers to a system with a processor core, a set of on-chip peripherals, on-chip memory and interfaces to off-chip memory all implemented on a single Altera device.

In this document, the *Designing Multiprocessor Systems* chapter describes the features of the Nios II processor and SOPC Builder tool that are useful for creating systems with two or more processors. The *Building & Running Software on a Nios II Multiprocessor System* chapter guides you through a step-by-step process for building a multiprocessor system containing three processors that all share a memory buffer. Using the Nios II IDE, you will create and debug three software projects, one for each processor in the system.

After completing this document, you will have the knowledge to perform the following:

- Build an SOPC Builder system containing more than one Nios II processor.
- Safely share resources between processors avoiding data corruption.
- Build software projects for multiprocessor systems using Nios II IDE
- Debug multiple software projects running on multiple processors using Nios II IDE.

This chapter assumes that you are familiar reading and writing embedded software and that you have read and followed the step-by-step procedures for building a microprocessor system in the *Nios II Hardware Development Tutorial*. This tutorial can be found on the Nios II Processor Literature page at <http://www.altera.com/literature/lit-nio2.jsp>.

Benefits of Multiprocessor Systems

Multiprocessor systems possess the benefit of increased performance, but nearly always at the price of significantly increased system complexity. For this reason, the use of multiprocessor systems has historically been limited to workstation and high-end PC computing using a complex method of load-sharing often referred to as symmetric multi processing (SMP). While the overhead of SMP is typically too high for most embedded systems, the idea of using multiple processors to perform different tasks and functions on different processors in embedded applications (asymmetrical) is showing increased interest. Altera FPGAs provide an ideal platform for developing asymmetric embedded multiprocessor systems since the hardware can easily be modified and tuned using the SOPC Builder tool to provide optimal system performance. Furthermore, with a powerful integration tool like SOPC Builder, different system configurations can be designed, built, and evaluated very quickly.

Nios II Multiprocessor Systems

Nios II version 5.0 and higher includes features to help with the creation and debugging of multiprocessor systems. Multiple Nios II processors are able to efficiently share system resources thanks to the multimaster friendly slave-side arbitration capabilities of the Avalon bus fabric. Since the capabilities of SOPC Builder now allow users to almost effortlessly add as many processors to a system as desired, the design challenge of building multiprocessor systems no longer lies in the arranging and connecting of hardware components. The design challenge in building multiprocessor systems now lies in writing the software for those processors so they operate efficiently together, and do not conflict with one another.

To aid in the prevention of multiple processors interfering with each other, a hardware mutex core is included in the Nios II Development Kits. The hardware mutex core allows different processors to claim ownership of a shared resource for a period of time. This temporary ownership of a resource by a processor prevents the shared resource from becoming corrupted by the actions of another processor. To learn more about the hardware mutex core, see the *Mutex Core with Avalon Interface* in the *Nios II Processor Reference Handbook*.

Performing software debug on multiprocessor systems is made easier with the Nios II IDE, allowing users to launch and stop

software debug sessions on different processors with a single operation.

Hardware Design Considerations

Nios II multiprocessor systems are split into two main categories, those that share resources, and those in which each processor is autonomous and does not share resources with other processors.

Autonomous Multiprocessors

While autonomous multiprocessor systems contain multiple processors, these processors are completely autonomous and do not communicate with the others, much as if they were completely separate systems. Systems of this type are typically less complicated and pose fewer challenges since by design, the system's processors are incapable of interfering with each other's operation. [Figure 1](#) shows a block diagram of two autonomous processors in a multiprocessor system.

Figure 1: Autonomous Multiprocessor System

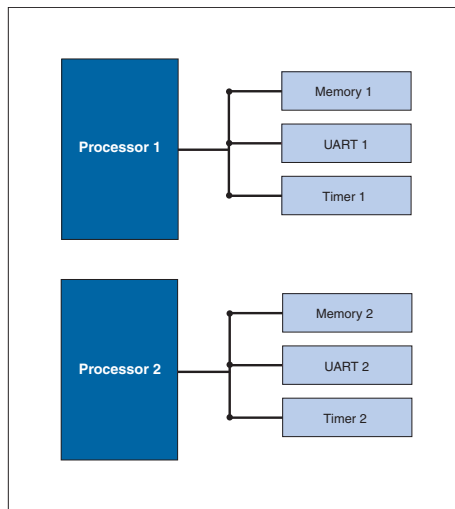

Multiprocessors that Share Resources

Multiprocessor systems that share resources can pose many more challenges. While Nios II has included features making it possible to reliably implement multiprocessor systems that share resources, the creation of such systems is not necessarily a straightforward venture. It is advised that you complete this tutorial and fully understand its recommendations before attempting to create a resource-sharing multiprocessor system.

Sharing Resources in a Multiprocessor System

Resources are considered *shared* when they are available to be accessed by more than one processor. Shared resources can be a very powerful aspect of multiprocessor systems, but care must be taken when deciding which system resources are shared, and how the different processors will cooperate regarding the use of resources. [Figure 2](#) shows a block diagram of a multiprocessor which shares resources.

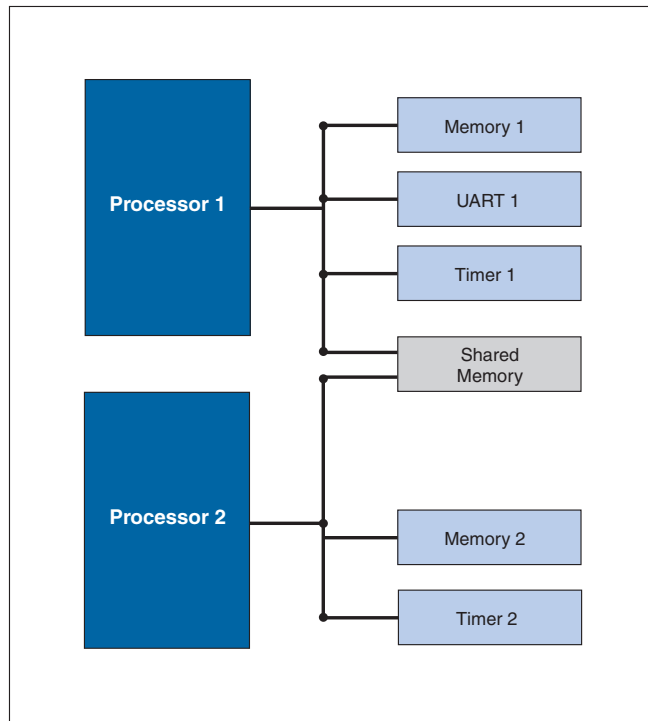
Figure 2: Multiprocessor System with Shared Resource

Resources can be made shareable by simply connecting them to multiple processor bus masters in the connection matrix of SOPC Builder, but that in no way guarantees that the processors that share them will do so non-destructively. The software running on each processor is responsible for coordinating access to shared resources with the system's other processors. [Figure 3](#) shows a multiprocessor system in which two processors share an on-chip memory. The on-chip memory is considered shared because the data master ports of both processors are connected to the same slave port of the memory. Since `cpu1` and `cpu2` are both physically capable of writing blocks of data to the shared memory at the same time, the software for those processors must be written carefully to protect the integrity of the data stored in the shared memory.

Figure 3: Multiprocessor System Sharing On-Chip Memory

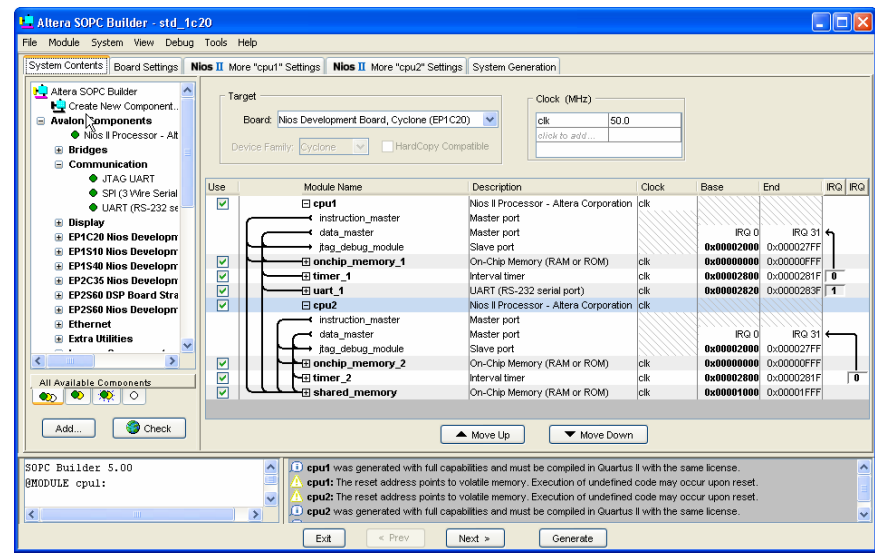

Sharing Memory

The most common type of shared resource in multiprocessor systems is memory. Shared memory can be used for anything from a simple flag whose purpose is to communicate status between processors, to complex data structures that are collectively computed by many processors simultaneously.

If a memory component is to contain the program memory for more than one processor, each processor sharing the memory is required to use a separate area for code execution. The processors cannot share the same area of memory for program space. Each processor must have its own unique `.text`, `.rodata`, `.rwdata`, `heap`, and `stack` sections. See [Software Design Considerations](#) for information on how to make sure each processor sharing a memory component for program space uses a dedicated area within that memory.

If a memory component is to be shared for data purposes, its slave port needs to be connected to the data masters of the processors that are sharing the memory. Sharing data memory between multiple processors can be trickier than sharing instruction memory due to the fact that data memory can be written to as well as read. If one processor is writing to a particular area of shared data memory at the

same time another processor is reading or writing to that area, data corruption will likely occur, causing application errors at the very least, and possibly a system crash.

The processors sharing memory need a mechanism to inform one another when they are using a shared resource, so the other processors do not interfere.

The Hardware Mutex Core

The Nios II processor allows the handling of protection of shared resources with its hardware mutex core feature. This hardware mutex core is not an internal feature of the Nios II processor, but a small SOPC Builder component named **Mutex**.

The term mutex stands for “mutual exclusion”, and a mutex does exactly as its name suggests. A mutex allows cooperating processors to agree that one of them should be allowed mutually exclusive access to a hardware resource in the system. This is useful for the purpose of protecting resources from data corruption that can occur if more than one processor attempts to use the resource at the same time.

The mutex core acts as a shared resource, providing an atomic “test and set” operation in which a processor may test if the mutex is available and if so, acquire it in a single operation. When the processor is finished using the shared resource associated with the mutex, the processor releases the mutex. At this point, another processor may acquire the mutex and use the shared resource. Without the mutex, this kind of function would normally require two separate “test” and “set” instructions between which, another processor could also test for availability and succeed. This situation would leave two processors both thinking they successfully acquired mutually exclusive access to the shared resource when clearly they did not.

It is important to note that the mutex core does not physically protect resources in the system from being accessed at the same time by multiple processors. The software running on the processors is responsible for abiding by the rules. The software must be designed to always acquire the mutex before accessing its associated shared resource.

Another kind of mutex, called a software mutex is common in many operating systems for providing the same protection of resources. The difference is that a software mutex is purely a software construct that is used to protect hardware resources from being corrupted by

Sharing Resources in a Multiprocessor System

multiple *processes* running on the same processor. A hardware mutex core is an SOPC Builder component with an Avalon interface that uses logic to guarantee only one *processor* is granted *lock* of the mutex at any given time. This means that as long as every processor waits until it locks the mutex before using the associated shared resource, the resource will be protected from corruption due to simultaneous access by multiple processors. Each processor must first request a lock of the mutex core before accessing the associated shared resource.

Nios II Systems Without a Mutex Core

In most cases, a mutex core should be used to protect any resource shared between multiple processors. However, there are some limited cases when a mutex core may not be necessary. Such cases might include one way or circular message buffer arrangements where only one processor ever writes to a particular set of memory locations. However, sharing resources safely without a mutex core can be complicated. When in doubt, using the mutex core is highly recommended.

Sharing Peripherals Between Multiple Processors

In general, with the exception of the mutex core, Nios II does not support the sharing of non-memory peripherals between multiple processors.

Sharing peripherals in multiprocessor systems presents some difficult challenges, and is generally considered to be inefficient system design. The biggest problems arise for peripherals with interrupts. If a peripheral is allowed to interrupt all the processors which share it, there is no reliable way to guarantee which processor will respond first and service that interrupt. Additionally, if the peripheral is used as an input device for multiple processors, it becomes difficult to determine which processor is supposed to collect given input from the device. While it is conceivable that a complex system of handshaking could be created to handle these scenarios, it is beyond the scope of this document, and is unsupported by the Nios II HAL library. For more information on the Nios II HAL Library, see the *Nios II Software Developer's Handbook*.

Altera recommends that each non-memory peripheral be accessible by only one processor in the system. If other processors require use of the peripheral, they should use a message buffer that is either mutex-protected or otherwise multiprocessor safe when communicating with the processor that is connected to that peripheral.

When building any system, especially a multiprocessor system, it is advisable to only make connections between peripherals that require communication. For instance, if a processor runs from and uses only one on-chip memory, there is no need to connect that processor to any other memory in the system. Physically disconnecting the processor from memories it is not using both saves FPGA resources and guarantees the processor will never corrupt those memories.

In single processor systems, SOPC Builder will usually make intelligent default choices for connecting master and slave components. However, in multiprocessor systems the need to connect different components is much more design dependent. Therefore, when designing multiprocessor systems, it is important to explicitly verify that each component is connected appropriately.

Multiprocessors & Overlapping Address Space

In single-processor systems, it is typically prohibited for more than one slave peripheral to occupy the same address space because it will cause conflicts. In multiprocessor systems however, it is possible for separate slave peripherals to occupy the same base address and not conflict, as long as each of those peripherals is exclusively mastered by a different processor. Since every slave peripheral is not necessarily mastered by every processor, each processor may have a different view of the system. If processor A is connected to a slave peripheral mapped to address 0x4000, processor B may connect to a separate slave peripheral, also mapped to address 0x4000, as long as processor A is not connected to processor B's slave peripheral and processor B is not connected to processor A's slave peripheral. See [Figure 4](#) for a block diagram of a multiprocessor system which has different slave peripherals mapped to the same base address. [Figure 5](#) shows an example in SOPC Builder of a multiprocessor system with different slave peripherals mapped to the same base address.

Figure 4: Multiprocessor Slave Peripherals Mapped to the Same Base Address

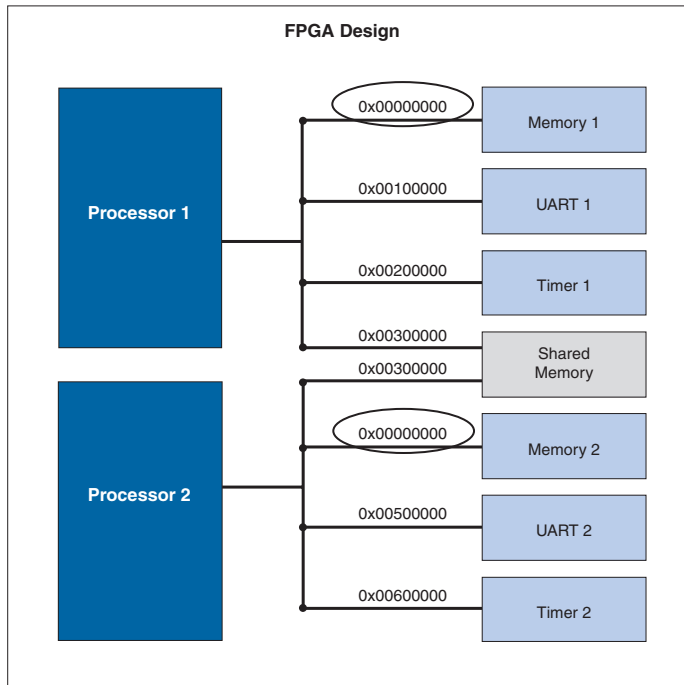
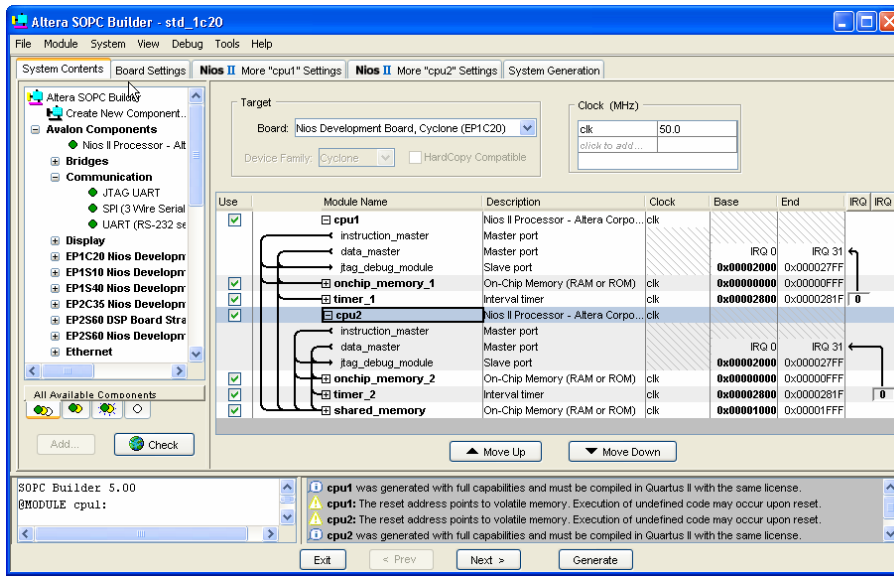

Figure 5: SOPC Builder Example of Multiprocessor Slave Peripherals Mapped to the Same Base Address



Software Design Considerations

Creating and running software on multiprocessor systems is much the same as for single-processor systems, but requires the consideration of a few additional aspects. Many of the software design issues described in this section are dictated by how the system's hardware is architected.

Program Memory

When creating multiprocessor systems, you may want to run the software for more than one processor out of the same physical memory device. Software for each processor must be located in its own unique region of memory, but those regions are allowed to occupy the same physical memory device. For instance, imagine a two-processor system where both processors run out of SDRAM. The software for the first processor requires 128 Kbytes of program memory, and the software for the second processor requires 64Kbytes. The first processor could use the region between 0x0 and

Software Design Considerations

0x1FFFF in SDRAM as its program space, and the second processor could use the region between 0x20000 and 0x2FFFF.

Nios II and SOPC Builder provide a simple scheme of memory partitioning that allows multiple processors to run their software out of different regions of the same physical memory. The partitioning scheme uses the exception address for each processor, which is set in SOPC Builder, to determine the region of memory from which each processor will be allowed to run its software. Although the Nios II IDE is ultimately responsible for the linking of the processors' software and determining where the software will reside in memory, Nios II IDE looks at the exception addresses that were set for each processor in SOPC Builder to calculate where the different code sections will be linked. The Nios II IDE provides each processor its own section within memory from which it can run its software. If the software for two different processors is linked to the same physical memory, then the exception address of each processor is used to determine the base address of the region which that processor's software can occupy. The end address of the region is determined by the next exception address found in that physical memory, or the end of that physical memory, whichever comes first.

For any single or multiprocessor system, there are five primary code sections that need to be linked to fixed addresses in memory for each processor. These sections are:

- `.text` — the actual executable code
- `.rodata` — any constant data used in the execution of the code
- `.rdata` — where read/write variables and pointers are stored
- `heap` — where dynamically allocated memory is located
- `stack` — where function call parameters and other temporary data is stored

See [Figure 6](#) for a memory map of how these sections are typically linked in memory for a single processor Nios system.

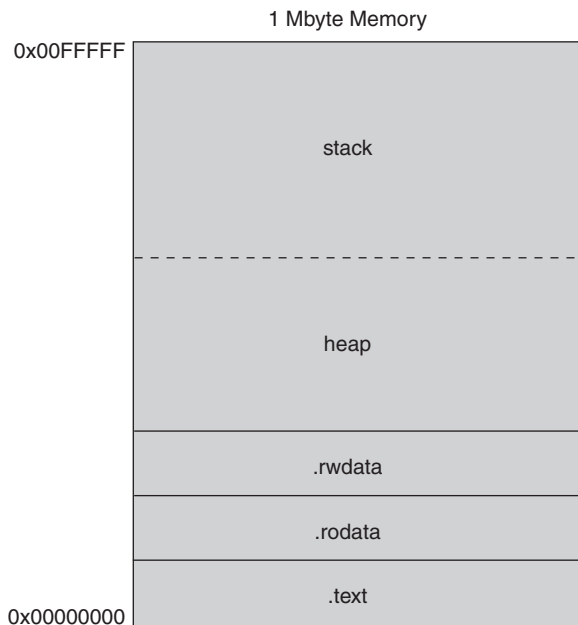
Figure 6: Single Processor Code Linked in Memory Map

In a multiprocessor system, it may be desirable to use a single memory to store all the code sections for each processor. In this case, the exception address set for each processor in SOPC Builder is used to define the boundaries between where one processor's code sections end and where the next processor's code sections begin.

For instance, imagine a system where SDRAM occupies the address range 0x0 – 0xFFFF and processors A, B and C each need 64 Kbytes of SDRAM to run their software. By using SOPC Builder to set their exception addresses 64 Kbytes apart in SDRAM, Nios II IDE will automatically partition SDRAM based on those exception addresses. See [Figure 7](#) for a memory map showing how the SDRAM will be partitioned in this example system.

Figure 7: Partitioning of SDRAM Memory Map for Three Processors

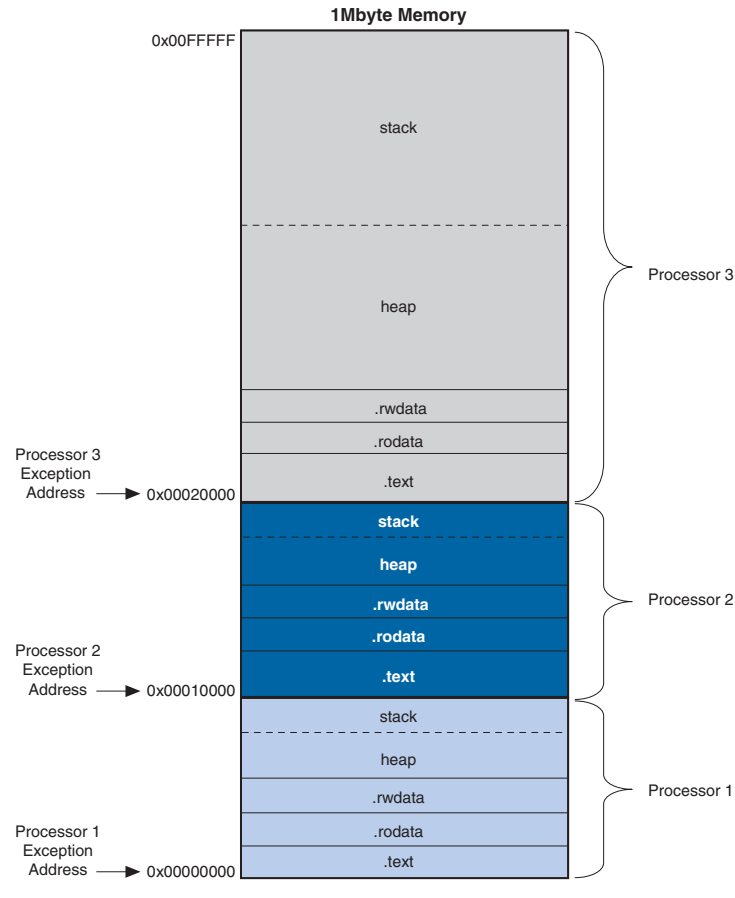

Note that the lower six bits of the exception address are always set to 0x20. Offset 0x0 is where Nios II must run its reset code, so the exception address must be placed elsewhere. The offset of 0x20 is chosen because it corresponds to one instruction cache line. The 0x20 bytes of reset code initializes the instruction cache, and then branches around the exception section to the system startup code.

Care must be taken when partitioning a physical memory to contain the code sections of multiple processors. There are no safeguards in SOPC Builder or Nios II IDE that guarantee you have provided enough code space for each processor's stack and heap in the partition. If inadequate code space is allotted in memory, the stack and heap may overflow and corrupt the processor's code execution.

Boot Addresses

In multiprocessor systems, each processor must boot from its own piece of memory. More than one processor may not boot from the same bit of executable code at the same address in the same non-volatile memory. Boot memory can also be partitioned, much like program memory can, but the notion of sections and linking is not a concern as boot code typically just copies the real program code to where it has been linked in RAM, and then branches to the program code. To boot multiple processors out of separate regions with the same non-volatile memory device, simply set each processor's reset address to the location from where you wish to boot that processor. Be sure you leave enough space between boot addresses to hold the intended boot payload. See [Figure 8](#) for a memory map of one physical flash device from which three processors can boot.

Figure 8: Flash Device Memory Map with Three Processors Booting

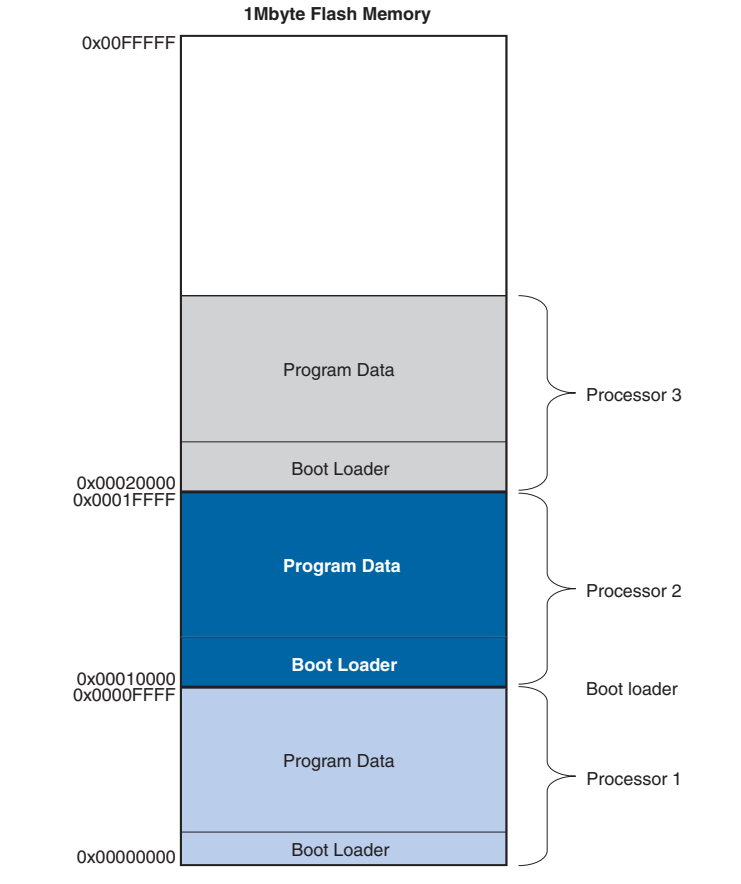

Nios II Flash Programmer is able to program bootable code for multiple processors into a single flash device. The flash programmer looks at the reset address of each processor and then uses that reset address to calculate the offset within the flash where the code will be programmed. See the *Nios II Flash Programmer User Guide* for details about the flash programmer.

Running & Debugging Multiprocessor Systems from the Nios II IDE

The Nios II IDE includes a number of features that can help in the development of software for multiprocessor systems. Most notable is the ability of the Nios II IDE to perform simultaneous on-chip debug for multiple processors. Multiple debug sessions can run at the same time on a multiprocessor system and can pause and resume each processor independently. Breakpoints can also be set individually per processor, so if one processor hits a breakpoint, it will not halt or affect the operation of the other processors. Lastly, debug sessions can be launched and stopped independently.

Debug sessions for multiple processors can also be launched in a single operation with the Nios II IDE, using a feature called *multiprocessor collections*. Multiprocessor collections are groups of debug configurations for individual processors that are combined under one configuration name. The benefit of a multiprocessor collection is that any time the collection is launched; the Nios II IDE individually launches each of the single debug configurations in the background. This allows users to launch debug sessions for multiprocessor systems without having to manually launch a session for each processor. Multiprocessor collections can also be stopped with one operation, however pausing and resuming multiprocessor collections together is not currently supported.

The launching and stopping of multiprocessor collections is not simultaneous, meaning the processors in the collection do not start executing code on the same clock cycle. In fact, there may be a delay of a few seconds between the individual processors being started. The purpose of multiprocessor collections is to make it more convenient to launch debug sessions for multiprocessor systems, not to synchronize the processors. If you want the multiple processors to start within a shorter period of time, a separate hardware or software mechanism will need to be constructed to enable this.



Building & Running Software on a Nios II Multiprocessor

Introduction

In this Tutorial, you will build a 3-processor Nios II system with SOPC Builder, starting with the standard example design as a template. Next, you will create 3 software projects in the Nios II IDE, one for each processor. The software for all 3 CPUs will generate messages to be displayed and use the hardware mutex core to put those messages in a shared message buffer. `cpu1` will continually check the message buffer for new messages, and if it finds one, will print it using the `jtag_uart`.

Hardware and Software Requirements

To use the design example in this tutorial, you must have the following:

- Quartus II Software version 5.0 or higher – Both Quartus II Web Edition and the fully licensed version will work with the example design.
- Nios II Development Kit version 5.0 or higher – There are five available kits which include a Nios development board and an Altera USB Blaster download cable (optional). You can use any of the following Nios II Development Kits:
 - Stratix II Edition
 - Stratix Edition
 - Stratix Professional Edition
 - Cyclone II Edition
 - Cyclone Edition

If you do not have a development board, you can follow the hardware development steps, but you will not be able to download the complete system to a working board.



You can download the Quartus II Web Edition software and the Nios II Development Kit, Evaluation Edition for free from the Altera Download Center at www.altera.com.

Before you begin, you must install the Quartus II software and Nios II development tools.

Creating the Hardware System

In the following steps you will create a multiprocessor system by starting with the standard hardware example design included in the Nios II development kit, and adding two additional processors, two additional timers, and a hardware mutex component. You can use the standard hardware example design for any of the Nios development boards, and the resulting system will run on that development board. If you do not have a Nios development board, you can still follow these steps to learn how to design multiprocessor hardware.

Getting Started with a Standard Example Design

To begin building a multiprocessor system sharing resources, perform the following steps:

Browse to the examples directory for your board. Each of the board-specific project files are found in the following directory: *<Nios II kit path>\examples\ \<Dev.Kit Device>\standard.qpf*. [Table 1](#) lists the names of the board-specific directories and Quartus II project file.

Table 1: Project File Directory		
Nios Development Board	Board-Specific Directory	Project File for Microprocessor Tutorial
Stratix II Edition	niosII_stratixII_2s60_es	standard.qpf
Stratix Edition	niosII_stratix_1s10 & niosII_stratix_1s10_es	standard.qpf
Stratix Professional Edition	niosII_stratix_1s40	standard.qpf
Cyclone II Edition	niosII_cycloneII_2c35	standard.qpf
Cyclone Edition	niosII_cyclone_1c20	standard.qpf

1. Copy the standard example design project directory for the board you are using to a working directory named **C:/Multiprocessor_Tutorial** or to a directory of your choice. Make sure the path has no spaces.
2. Open the Quartus II software.
3. Open the **standard.qpf** project file from the newly-created directory.
4. Choose **SOPC Builder** (Tools).



In this tutorial, you *must* name the hardware components exactly. If your component names differ from the names printed here, the software example will not work.

5. Right click **cpu** and select **Rename**.
6. Type **cpu1** to rename the processor then press **Enter**.
7. Right click **sys_clk_timer** and select **Rename**.
8. Type **cpu1_timer** and press **Enter**. This will be your timer for **cpu1**.

9. Click **Move Up** to move `cpu1_timer` under `cpu1`.

Adding a Second Processor

In the next series of steps, you will add a second Nios II processor to the system. A Nios II/s will be added because it is a good general-purpose choice.

To add a second processor, perform the following steps:

1. Double click **Nios II Processor – Altera Corporation** in the list of available components to add a second Nios II processor to the system. Once selected, the Nios II Core wizard is displayed.
2. Select **NiosII/s** as the type of processor and click **Finish**.
3. Click the **JTAG Debug Module** tab.
4. Select **Level 1** as the debugging level for this processor and click **Finish**.

You will see error messages in the SOPC Builder messages window. This is because SOPC Builder does not know that you plan to connect this processor with other components in the system. Ignore the error messages for now. You will fix these errors in later steps.

5. Right click the newly-added processor and select **Rename**.
6. Type `cpu2` and press **Enter**.
7. Use **Move Up** to move `cpu2` under `cpu1_timer`.

Adding a Third Processor

In the next series of steps, you will add a third Nios II processor to the system. An economy (NiosII/e) variety of Nios II will be added to demonstrate that any Nios II variety processor can be used in a multiprocessor system.

To add the third processor, perform the following steps:

- ✓ Repeat steps 1-9 above to add a third Nios II processor with the following exceptions:

In the Nios II Core wizard, select **NiosII/e** as the type of processor for the third processor in the system.
Type `cpu3` to rename the third processor added to the system.
Click **Move Up** to move `cpu3` under `cpu2`.

Adding a Timer for `cpu2`

As mentioned earlier, it is typically not recommended for multiple processors to share non-memory peripherals, so here you will add separate timer peripherals for each processor in this system.

To add a timer for `cpu2`, perform the following steps:

1. Double click **Interval Timer** in the list of available components to add a timer for `cpu2`.
2. Accept the default settings in the Interval Timer wizard and click **Finish**.
3. Right click the new timer component and select **Rename**.
4. Type `cpu2_timer` and press **Enter**. This will be your timer for `cpu2`.
5. Click **Move Up** to move `cpu2_timer` under `cpu2`.
6. Using the connection matrix, connect `cpu2_timer` to the data master for `cpu2` only. Disconnect `cpu2_timer` from all other masters.

If you do not see the connection matrix when you move the mouse over the SOPC Builder connections, choose **View > Show Connections** (SOPC Builder menu).

7. Enter 0 in the IRQ column for `cpu2_timer`. This allows `cpu2_timer` to interrupt `cpu2` with a priority setting of 0, which is the highest priority.

Adding a Timer for `cpu3`

To add a timer for `cpu3`, perform the following steps:

1. Double Click **Interval Timer** in the list of available components to add a timer for `cpu3`.
2. Accept the default setting in the Interval Timer wizard and click **Finish**.
3. Right click the new timer component and select **Rename**.
4. Type `cpu3_timer` and press **Enter**. This will be your timer for `cpu3`.
5. Click **Move Up** to move `cpu3_timer` under `cpu3`.
6. Using the connection matrix, connect `cpu3_timer` to the data master for `cpu3` only. Disconnect `cpu3_timer` from all other masters.
7. In the **IRQ** column for `cpu3_timer`, enter 0. This allows `cpu3_timer` to interrupt `cpu3` with a priority setting of 0. This is the highest priority.

Adding a Hardware Mutex

You are building a multiprocessor system that shares a data memory between processors, so it is essential that a hardware mutex component be included to enable protection of that memory from data corruption.

To add the hardware mutex, perform the following steps:

1. Double click **Mutex** under **Others** in the list of available components to add a mutex core to the system.
2. Accept the defaults in the Mutex wizard and click **Finish**.
3. Right click **Mutex** and select **Rename**.
4. Type `message_buffer_mutex` and press **Enter**.

5. Using the connection matrix, connect **message_buffer_mutex** to the data masters for each processor. This allows all three processors to access **message_buffer_mutex**.

Adding a Message Buffer Memory

Here you will add an on-chip memory to the system that will be used as a message buffer to pass messages between processors. This memory will be shared by all processors in the system. The processors will use the mutex core added in the previous steps to protect the memory's contents from corruption.

To add a message buffer memory perform the following steps:

1. Double click **On-chip Memory** under **Memory** in the list of available components. The On-Chip Memory wizard is displayed.
2. Under **Size**, type 1 and select **Kbytes** in the **Total Memory Size** box.
3. Click **Finish**.
4. Right click **on-chip memory_0** and select **Rename**.
5. Type **message_buffer_ram** and press **Enter**. This memory will be used as a message buffer for the three processors in your multiprocessor system.

Connecting Shared Resources

Now you need to connect all the resources that will be shared between processors in the system using SOPC Builder's connection matrix.

To connect all the resources in the system shared by the multiple processors, perform the following steps:

1. Using the connection matrix, connect **sdram** to the instruction and data masters for each processor, allowing all three processors to access **sdram**.

All the connection dots for the sdram should be solid black.

Creating the Hardware System

- Using the connection matrix, connect `ext_ram_bus` to the instruction and data masters for each processor, allowing all three processors to access external RAM and FLASH.
- All the connection dots for `ext_ram_bus` should be solid black.
- Using the connection matrix, connect `message_buffer_ram` to the data masters for each processor, allowing all three processors to access that memory.
- Remove the default connection between `message_buffer_ram` and the `cpu1` instruction master, as no software will be run from `message_buffer_ram`.
- Choose **System > Auto-Assign Base Addresses** to give every peripheral a unique base address.

Figure 9 shows you what your system should look like after completing the tutorial up to this point.

Figure 9: Connect Shared Resource Example

The screenshot displays the Altera SDC Builder interface. On the left, a tree view shows the system components, including three Nios II processors (cpu0, cpu1, cpu2) and various peripheral modules. The central area is a connection matrix where lines connect modules to specific ports (Instruction Master, Data Master, Slave Master, Slave Port). The right side features a table with columns for Module Name, Description, Clock, Base, End, and I/O signals. The table lists components like 'cpu0', 'cpu1', 'cpu2', 'ext_ram_bus', 'message_buffer_ram', and 'sdram_controller'. At the bottom, a status bar shows several warning messages, such as 'cpu0: The reset address points to volatile memory' and 'cpu2: The reset address points to volatile memory'.

Setting Reset and Exception Addresses

In the following steps, you will set the reset and exception addresses for all three processors. If you recall from [Program Memory](#) on page 9 the exception addresses are what determine how code memory is partitioned between processors. In this tutorial, each of the three processors will run its software from 1Mbyte of SDRAM, so you will set each processor's exception address within SDRAM, each separated by 0x100000 (1Mbyte).

Setting Reset and Exception Addresses for cpu1

To set the Reset and Exception Addresses for **cpu1**, perform the following steps:

- ✓ Click the “More “cpu1” settings” tab and set the **Memory Module** and **Offset** fields to match [Table 2](#).

Table 2: cpu1 Reset & Exception Addresses			
Processor Function	Memory Module	Offset	Address
Reset Address	ext_flash	0x00000000	0x00000000
Exception Address	sdram	0x00000020	0x01000020

Setting Reset and Exception Addresses for cpu2

To set the **Reset** and **Exception Addresses** for **cpu2**, perform the following steps:

- ✓ Click the “More “cpu2” settings” tab and set the **Memory Module** and **Offset** fields to match [Table 3](#).

Table 3: cpu2 Reset & Exception Addresses			
Processor Function	Memory Module	Offset	Address
Reset Address	ext_flash	0x00100000	0x00100000
Exception Address	sdram	0x00100020	0x01100020

Setting Reset and Exception Addresses for cpu3

To set the **Reset** and **Exception Addresses** for **cpu3**, perform the following steps:

- ✓ Click the “**More “cpu3” settings**” tab and set the **Memory Module** and **Offset** fields to match [Table 4](#).

Table 4: cpu3 Reset & Exception Addresses			
Processor Function	Memory Module	Offset	Address
Reset Address	ext_flash	0x00200000	0x00200000
Exception Address	s dram	0x00200020	0x01200020

Generating and Compiling the System

Here you will generate HDL for the system you just constructed in SOPC Builder, and then compile the project in Quartus to produce a programming file. To generate and compile the system, perform the following steps:

1. Click **Generate**.
2. When generation is complete, click **Exit** in SOPC Builder. This returns you to the Quartus II software. This may take a few moments.
3. If not automatically prompted to do so, update the system symbol by right clicking and selecting **Update Symbol**.

Notice that the symbol did not change. SOPC Builder was able to easily connect this complex, multiprocessor system without making any external changes to the system. With very little effort, a single-processor system has been turned into a pin-compatible three-processor system.
4. Select **File > Save** to save the Block Diagram File (.bdf) file.
5. Select **Start Compilation** (Processing menu) to compile the project in Quartus II.
6. When compilation is finished, select **Programmer** (Tools menu).

7. Choose **standard.sof** as a programming file.
8. Turn on the **Program/Configure** checkbox in the programmer and click **Start**.

Creating Software for the Multiprocessor System

In the following steps you will create six separate software projects for the multiprocessor system, one application project and one system library project for each processor in the system. You will then build, run and debug those software projects using Nios II IDE.

The software you will be running on this system uses the hardware mutex to share a message buffer. All three processors write messages to the message buffer. **cpu1** then reads the messages and prints them to the **jtag_uart**. You will notice that the same C file is run on each processor, but the processors are doing slightly different things. The way this is achieved is through the use of the **cpuid** feature of Nios II. In Nios II processor systems, a processor locks the mutex by writing the value of its **cpuid** control register to the **OWNER** field of the mutex register. The **cpuid** register holds a static value that uniquely identifies the processor in a multi-processor system. The software checks the processor's **cpuid** before executing any functions that are specific to a particular processor. If the **cpuid** is correct, it will execute the function.

Starting the Nios II IDE

Here you will start Nios II IDE and begin creating software projects for the three processors in the system. To start the Nios II IDE from SOPC Builder, perform the following steps:

1. Choose **SOPC Builder** (Tools menu).
2. Click the **System Generation** tab.
3. Click **Run Nios II IDE**.



If the Nios II IDE welcome screen is displayed, click **Workbench** to continue.

Creating a Software Project for `cpu1`

Here you will create software projects to run on each of the three processors in the system. The software will use the mutex to place messages in the message buffer to later be retrieved and printed by `cpu1`.

To create a software project for `cpu1`, perform the following steps:

1. When the Nios II IDE opens, choose **File > New > Project**.
2. Select **C/C++ Application** and click **Next**.
3. In the **Name** field, type `hello_multi_cpu1`.
4. Under **Select Target Hardware**, specify `cpu1` as the processor.
5. In **Select Project Template** list, select **Blank Project** as shown in [Figure 10](#).

Figure 10: New Project for cpu1

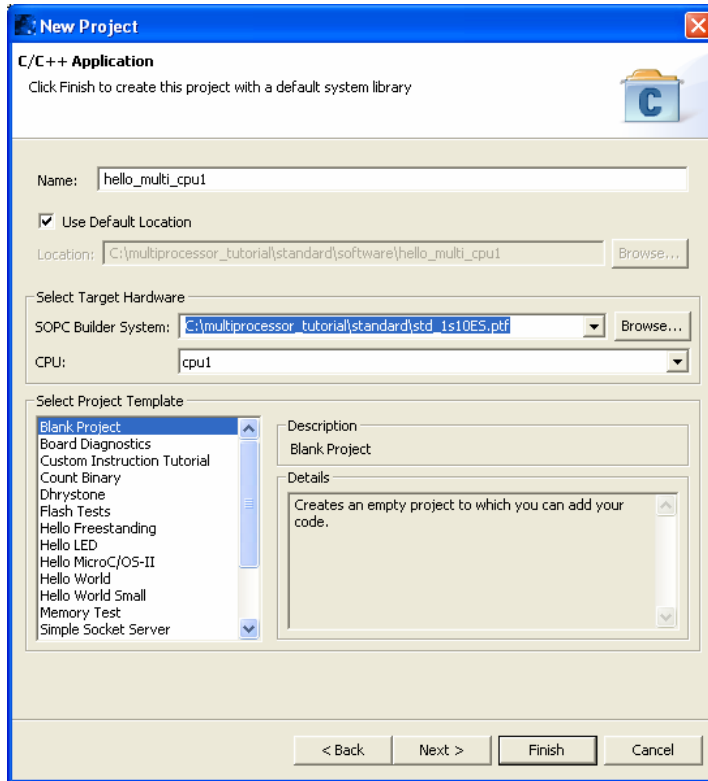

6. Click **Finish**. The Nios II IDE will generate a new C/C++ application project, and a corresponding system library project for **cpu1**.
7. Browse to the file **hello_world_multi.c** on the host PC.



This file is found with the *Nios II Multiprocessor Tutorial* on the Nios II Processor Literature page from www.altera.com/literature.

8. Right click **hello_world_multi.c** and select **copy**.

Creating Software for the Multiprocessor System

- Return to the Nios II IDE.
- Click the **Navigator** tab next to the **C/C++ Projects** tab.
- Right click the **hello_multi_cpu1** project and select **paste** to paste the copied C file into the project.
- Right click the system library project **hello_multi_cpu1_syslib**.
- Select **Properties**.
- In the left-hand window, select **System Library**.
- Select **jtag_uart** as **stdin**, **stderr**, and **stdout**.
- Select **cpu1_timer** as the **System clock timer**.
- Verify that **sdram** is selected for **Program memory**, **Read-only data memory**, **Read/write data memory**, **Heap memory**, and **Stack memory**. See [Figure 11](#) for an example of system library property settings.
- Click **OK**.

Figure 11: System Library Property Settings

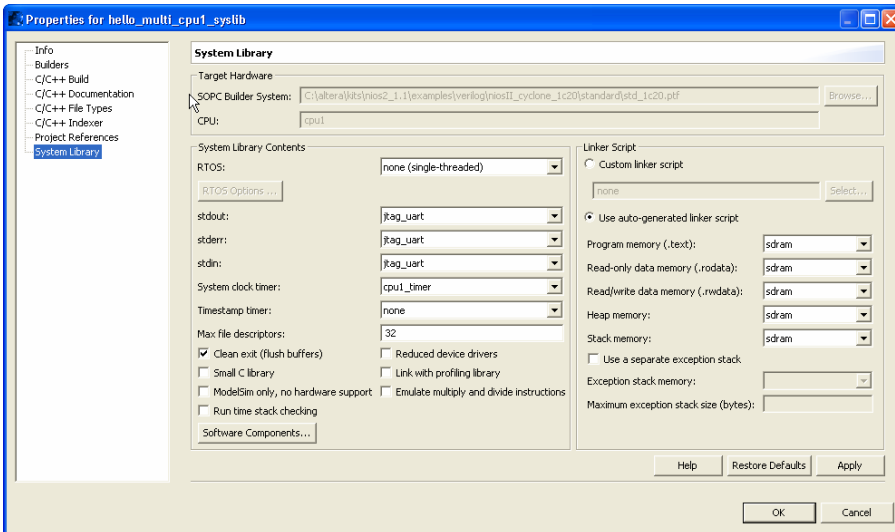

Creating a Software Project for `cpu2`

To create a software project for `cpu2`, perform the following steps:

1. Choose **File > New > Project**.
2. Select **C/C++ Application** and click **Next**.
3. In the **Name** field, type `hello_multi_cpu2`.
4. Under **Select Target Hardware**, specify `cpu2` as the processor.
5. In **Select Project Template**, choose **Blank Project**.
6. Click **Finish**.

The Nios II IDE will generate a new C/C++ application project, and a corresponding system library project for `cpu2`.

7. In the host PC file system, browse to the file `hello_world_multi.c`.



This file is found with the *Nios II Multiprocessor Tutorial* on the Nios II Processor Literature page from www.altera.com/literature.

8. Right click `hello_world_multi.c` and select **copy**.
9. Return to Nios II IDE and highlight the new project `hello_multi_cpu2`.
10. Click the **Navigator** tab next to the **C/C++ Projects** tab.
11. Right click the `hello_multi_cpu2` project and select **paste** to paste the copied C file into the project.
12. Right click the system library project `hello_multi_cpu2_syslib`.
13. Select **Properties**.
14. Select **System Library** in the left-hand window.
15. Select `cpu2_timer` as **System clock timer**.

Creating Software for the Multiprocessor System

16. Verify **null** is selected for **stdin**, **stderr**, and **stdout** since this processor is not connected to the **jtag_uart**.
17. Verify that **sdram** is selected for **Program Memory**, **Read-only data memory**, **Read/write data memory**, **Heap memory**, and **Stack memory**.
18. Click **OK**.

Creating a Software Project for **cpu3**

To create a software project for **cpu3**, perform the following steps:

1. Choose **File > New > Project**.
2. Select **C/C++ Application** and click **Next**.
3. In the **Name** field, type **hello_multi_cpu3**.
4. Under **Select Target Hardware**, specify **cpu3** as the processor.
5. In **Select Project Template**, choose **Blank Project**.
6. Click **Finish**.

The Nios II IDE will generate a new C/C++ application project, and a corresponding system library project for **cpu3**.

7. In the host PC file system, browse to the file **hello_world_multi.c**.



This file is found with the *Nios II Multiprocessor Tutorial* on the Nios II Processor Literature page from www.altera.com/literature.

8. Right click **hello_world_multi.c** and select **copy**.
9. Return to Nios II IDE and highlight the new project **hello_multi_cpu3**.
10. Click the **Navigator** tab next to the **C/C++ Projects** tab.
11. Right click the **hello_multi_cpu3** project and select **paste** to paste the copied C file into the project.

12. Right click system library project **hello_multi_cpu3_syslib**.
13. Select **Properties**.
14. Select **System Library** in the left-hand window.
15. Select **cpu3_timer** as **System clock timer**.
16. Verify **null** is selected for **stdin**, **stderr**, and **stdout** since this processor is not connected to the **jtag_uart**.
17. Verify that **sdram** is selected for **Program memory**, **Read-only data memory**, **Read/write data memory**, **Heap memory**, and **Stack memory**.
18. Click **OK**.

Building the Software Projects

Here you will build the three software projects you just created so they can be run on the processors in the system.

To build the three software projects, perform the following steps:

1. Click the **C/C++ Projects** tab at the top of the projects window in Nios II IDE
2. Right click the project **hello_multi_cpu1** and select **Build Project**.
3. Right click the project **hello_multi_cpu2** and select **Build Project**.
4. Right click the project **hello_multi_cpu3** and select **Build Project**.

If you encounter any errors in the builds, you must correct them and rebuild before continuing.

Setting up the Nios II IDE for Multiprocessor Debug

By default the Nios II IDE is set to not allow multiple active debug sessions. To enable multiple debug sessions, perform the following steps:

Creating Software for the Multiprocessor System

1. In the Nios II IDE, choose **Window > Preferences**.
2. Select **Nios II** and turn on **Allow multiple active run/debug sessions** as shown in [Figure 12](#).
3. Click **OK**.

Figure 12: Multiple Active Run/Debug Sessions

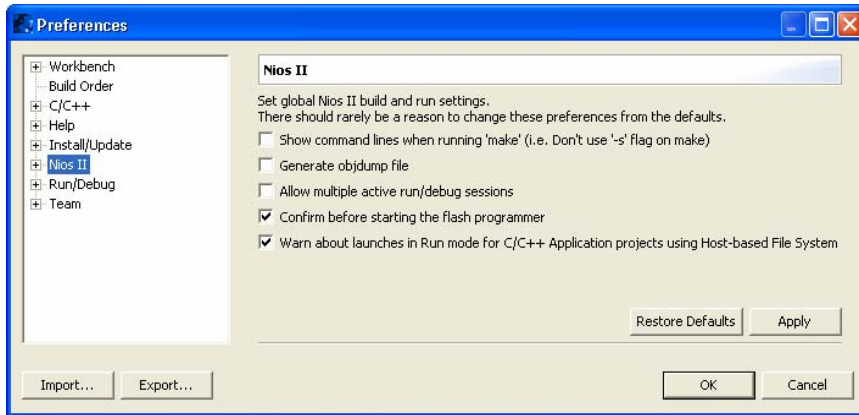

Creating a Debug Configuration for Each Processor

Here, you will create a run/ debug configuration for each of the target processors, which enable the running and debugging of the three software projects you just built on the processors in the system.

To create debug configurations for each processor, perform the following steps:

1. Select the **hello_multi_cpu1** project.
2. Choose **Run...** (Run menu).
3. Select **Nios II Hardware** in the **Configuration** list.
4. Click **New** in the lower left corner of the Run window.
5. Click the **Target Connection** tab.

6. Ensure the download cable you are using is selected in the **JTAG cable** field as shown in [Figure 13](#).

If the field reads **Automatic**<currently (*your correct download cable*)>, this is fine. You do not need to change it.

Figure 13: Create Debug Configuration

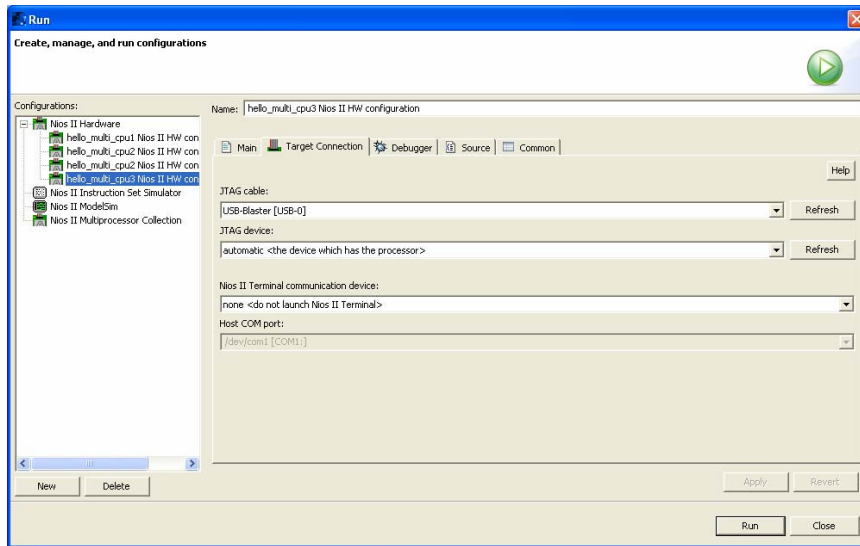

7. Click **Apply** then click **Close**.
8. Repeat steps 1 – 7 to create a run/debug configuration for each of the target processors.



Be sure you have selected the appropriate project when you create the run/debug configuration.

At this point, you have created a run/debug configuration for each processor in the system. You can now download, execute, and debug code on each of the processors individually, using the normal flow for running/debugging.

Creating a Multiprocessor Collection

Here you will create a multiprocessor collection which enables the launching and stopping of multiple processors as a single unit

To create this multiprocessor collection, perform the following steps:

1. Choose **Run...** (Run menu)
2. In the **Configurations** list, select **Nios II Multiprocessor Collection**.
3. Click **New** in the lower left corner of the **Run** window.
4. In the **Name** field, Type `hello_cpu_collection` as the name for this new multiprocessor collection.
5. Turn on **hello_multi_cpu1 Nios II HW configuration**, **hello_multi_cpu2 Nios II HW configuration**, and **hello_multi_cpu3 Nios II HW configuration** as shown in [Figure 14](#).
6. Click **Apply**.

Figure 14: Multiprocessor Collection Example

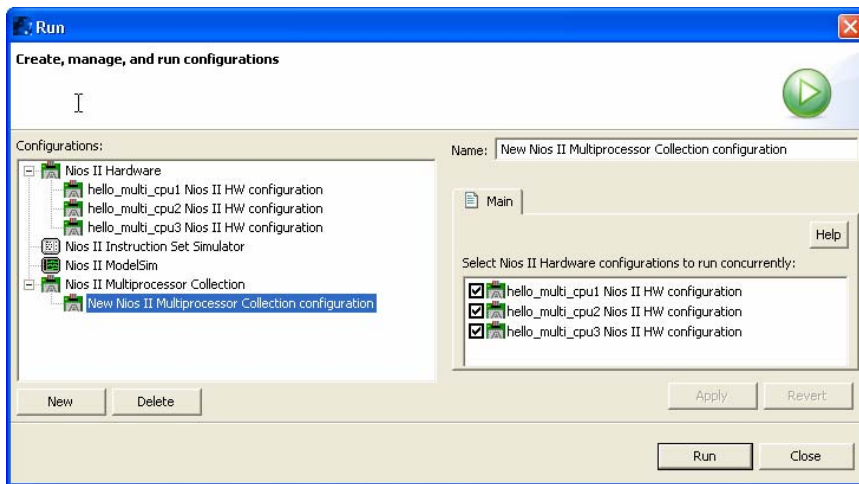

Starting the Multiprocessor Collection

Now you can start all the processors with a single mouse click. To start all the processors, perform the following steps:

1. Select the **hello_cpu_collection** configuration, and click **Run**. The Nios II IDE downloads the software to each processor, and then runs the software

Each processor begins executing code as soon as its code is downloaded; the processors do not start in unison.

2. After the launch finishes, you should see messages from all three processors being displayed on the terminal as shown in [Figure 15](#).

Figure 15: Multiprocessor Collection Messages

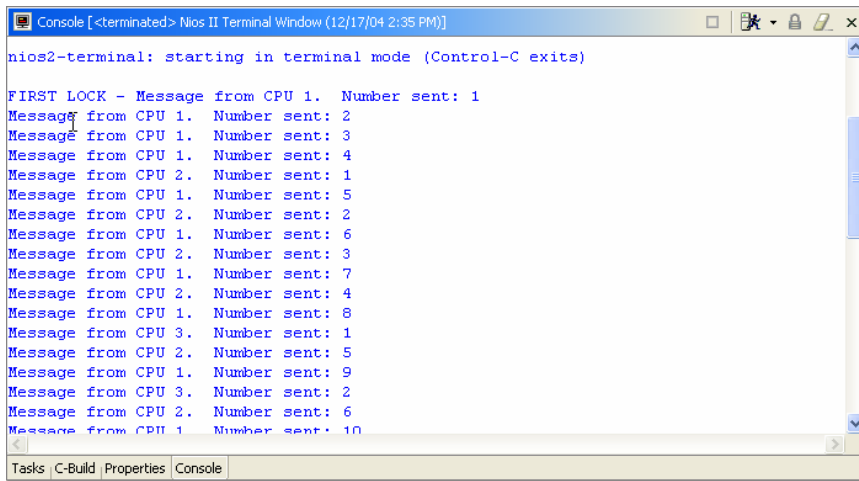
A screenshot of a Nios II Terminal Window titled "Console [<terminated> Nios II Terminal Window (12/17/04 2:35 PM)]". The terminal output shows a sequence of messages from three CPUs (CPU 1, CPU 2, and CPU 3) indicating the number of messages sent. The messages are: "FIRST LOCK - Message from CPU 1. Number sent: 1", "Message from CPU 1. Number sent: 2", "Message from CPU 1. Number sent: 3", "Message from CPU 1. Number sent: 4", "Message from CPU 2. Number sent: 1", "Message from CPU 1. Number sent: 5", "Message from CPU 2. Number sent: 2", "Message from CPU 1. Number sent: 6", "Message from CPU 2. Number sent: 3", "Message from CPU 1. Number sent: 7", "Message from CPU 2. Number sent: 4", "Message from CPU 1. Number sent: 8", "Message from CPU 3. Number sent: 1", "Message from CPU 2. Number sent: 5", "Message from CPU 1. Number sent: 9", "Message from CPU 3. Number sent: 2", "Message from CPU 2. Number sent: 6", and "Message from CPU 1. Number sent: 10". The terminal window has a standard Windows-style title bar and a taskbar at the bottom with tabs for "Tasks", "C-Build", "Properties", and "Console".

3. When you are done observing the terminal output, click the red square button (*stop*) above the terminal to close the terminal connection.

Debugging the Software Projects on the Board

In this section you will start all the processors using the multiprocessor collection, and set breakpoints on individual

Creating Software for the Multiprocessor System

processors. To start the processors and set individual breakpoints, perform the following steps:

1. Choose **Debug** (Run menu).
2. In the configurations list on the left, select the new collection you created under **Nios II multiprocessor collection** in the previous section.
3. Click **Debug**.



If a dialog box appears and asks you to switch to the debug perspective, click **Yes**.

Again, Nios II IDE will download and launch each software project on its respective processor, then pause each one at a breakpoint set on `main()`.

In the **Debug** view, you will see the processor collection listed at the top with each individual debug session listed below it, including the call stack.

4. Click the **main** call stack entry under the **cpu1** debug session.
5. Click **step over** in the toolbar menu to see **cpu1** step through its software commands.
6. Click **resume** in the toolbar menu to let **cpu1** run freely.

You will see that only messages from **cpu1** appear on the terminal as shown in [Figure 16](#).

Figure 16: cpu1 Debug Messages

```
Console [Nios II Terminal Window (12/17/04 2:51 PM)]
nios2-terminal: starting in terminal mode (Control-C exit)

FIRST LOCK - Message from CPU 1.  Number sent: 1
Message from CPU 1.  Number sent: 2
Message from CPU 1.  Number sent: 3
Message from CPU 1.  Number sent: 4
Message from CPU 1.  Number sent: 5
```

7. Click the **main** call stack entry under the **cpu2** debug session.

- Click **resume** in the toolbar menu to let **cpu2** run uninterrupted.

You will now see that messages from both **cpu1** and **cpu2** appear on the terminal as shown in [Figure 17](#).

Figure 17: cpu1& cpu2 Debug Output

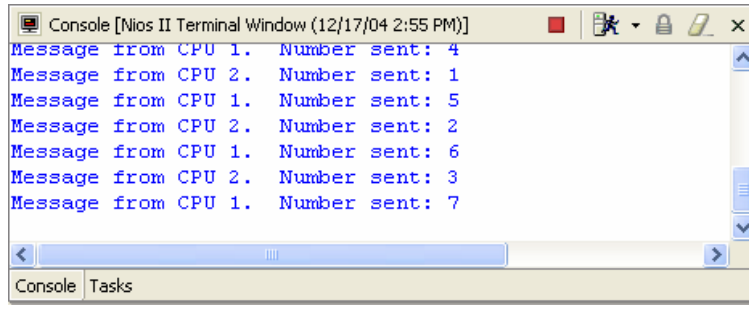

- In the **Debug** view, click the multiprocessor collection at the top of the list.
- Click the red square button (*stop*) to stop the debug sessions for all three processors.

You're done! You've now constructed, built software projects for, and debugged software on your first Nios II multiprocessor system. You have also learned how to use the **Mutex** component to share system resources between processors. Feel free to experiment with the system you've created and find interesting new ways of using multiple processors in an Altera FPGA.

We recommend you save this system to use as a starting point next time you wish to create a multiprocessor system.

